

Ergonomic Accessories

Improve safety, ergonomics, quality and tooling reliability



Guided Collars

Minimize tool vibration from sockets and extensions

What do our customers have to say about the product?

"We have prevented countless operator injuries by using these products, and I would recommend their use to anyone who is interested in employee safety."

Advanced Quality Engineer - Automotive Seating Company Corporate Headquarters

"These products extended socket and extension life on one application in particular, from 3-4 days to 3-4 weeks."

Tooling Engineer - Automotive Assembly Plant Georgetown, KY

"We have extended the life of our attachments and tooling as well as reduced vibration levels experienced by tooling operator, while improving the C_{PK} consistency of our tool torques."

Tooling Engineer - Automotive Seating Company St. Thomas, ON Canada

Ergonomic Accessories can help to improve:

- **Ergonomics** - significantly reduce the transfer of vibration to the operator.
- **Safety** - minimize the pinch hazard between the tool and the extension.
- **Product Quality** - reduce the potential for product damage by helping to prevent tool contact with finished surfaces and cross-threading caused by improper fastener installation.
- **Tool Torque Quality** - assure more consistent driving torque and improve capability.
- **Tooling Reliability** - Ergonomic accessories incorporate a heavy-duty bearing that minimizes wobble and reduces side-loading to reduce premature tool wear and improve tool reliability.

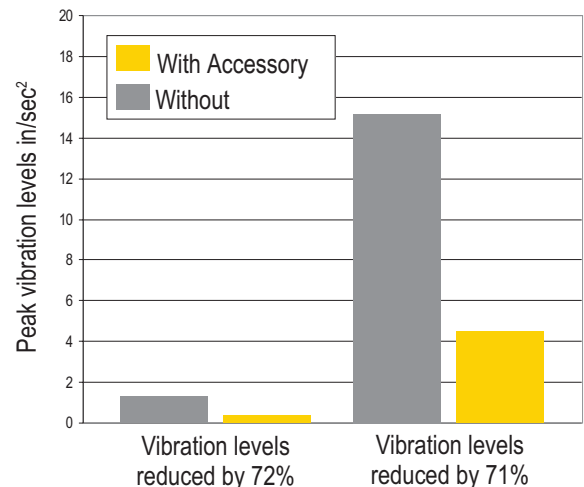

Independent tests show Guided Extension Collars reduce vibration by 72%!

Guided Collars use a heavy-duty bearing that minimizes wobble and reduces side-loading to reduce premature tool wear and improve tool reliability. Either extension or socket collars are available.



Assembly Technologies

Toll-Free: (877) 709-8006

Tel: (440) 461-5500

www.StanleyAssembly.com

Guided Extension Collars

QPM Guided Extension Collars

Collar Part No.	Output	Sq. Drive
20D243003	A13	3/8"
20D243104	A14	3/8"
20D243203	A18	3/8"
20D243206	A18	1/2"
20D243303	A19	3/8"
20D243306	A19	1/2"
20D243406	A22	1/2"

Each collar requires one Ultralite extension

Extension Length	Ultralite	
	3/8 SD P/N	1/2 SD P/N
4" (10cm)	20D124404	20D124504
6" (15cm)	20D124406	20D124506
8" (20cm)	20D124408	20D124508
10" (25cm)	20D124410	20D124510
12" (30cm)	20D124412	20D124512

Ultralight extensions offer up to 50% weight reduction over standard extensions.

Ball bearings allow free movement of the attachment while reducing side loading forces to the square drive and inner drive components.

A steel support sleeve ensures the tool drive axis and the collar are concentric with each other.

The collar mounts to the original tool packing cap or reaction bar nut.

Three dog-point set screws (not shown) lock the main body onto the steel support sleeve.

UHMW polyethylene sleeve provides a slight interference fit with the attachment and reduces wobble.

An aluminum main body minimizes weight.

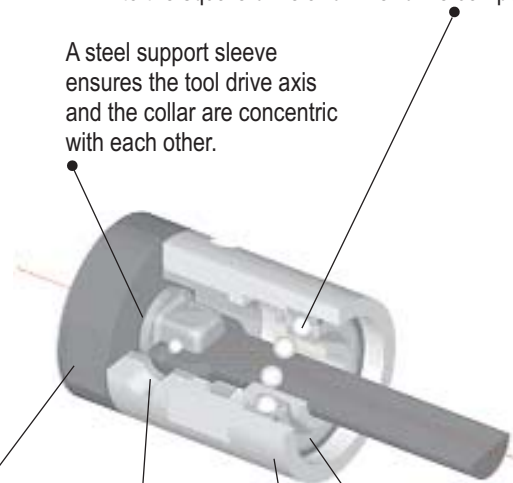

PinchPoint Protectors

Minimize operator pinch hazard at the socket-tool interface

Rugged, reliable Ergonomic PinchPoint Protectors are easy to install and use:

QPM PinchPoint Protectors

Part No.	Output	Sq. Drive
20D243002	A13	3/8"
20D243103	A14	3/8"
20D243202	A18	3/8"
20D243205	A18	1/2"
20D243302	A19	3/8"
20D243305	A19	1/2"
20D243405	A22	1/2"

- PinchPoint Protectors replace standard packing caps on QPM angle-head outputs.
- Rugged UHMW polyethylene sleeved construction provides outstanding strength and durability.
- I.D. clearance allows sockets to turn freely.
- Hollow lock set screws enable access to the square drive release pin for fast, easy socket installation and removal.



STANLEY

Assembly Technologies

Toll-Free: (877) 709-8006

Tel: (440) 461-5500

www.StanleyAssembly.com

Stanley Output Accessories

ErgoTorqTM PinchPoint Protectors

- Minimize operator pinch hazard at the socket-tool interface
- Minimize extension wobble



ErgoTorq PinchPoint Protectors can help to improve:

- **Ergonomics** - ErgoTorq PinchPoint Protectors significantly reduce the transfer of vibration to the operator.
- **Safety** - ErgoTorq PinchPoint Protectors minimize the pinch hazard between the tool and the extension.
- **Product Quality** - ErgoTorq PinchPoint Protectors reduce the potential for product damage by helping to prevent tool contact with finished surfaces and cross-threading caused by improper fastener installation.
- **Tool Torque Quality** - ErgoTorq PinchPoint Protectors assure more consistent driving torque and improve capability.
- **Tooling Reliability** - ErgoTorq PinchPoint Protectors incorporate a heavy-duty bearing that minimizes wobble and reduces side-loading to reduce premature tool wear and improve tool reliability.

Rugged, reliable ErgoTorq PinchPoint Protectors are easy to install and use:

- PinchPoint Protectors replace standard packing caps on QPM angle-head outputs.
- Rugged UHMW polyethylene sleeved construction provides outstanding strength and durability.
- I.D. clearance allows sockets to turn freely.
- Hollow lock set screws enable access to the square drive release pin for fast, easy socket installation and removal.

QPM PinchPoint Protectors

Part No.	Output	Square Drive
20D243002	A13	3/8"
20D243102	A14	3/8"
20D243205	A18	1/2"
20D243202	A18	3/8"
20D243305	A19	1/2"
20D243302	A19	3/8"
20D243408	A22	1/2"



To Whom It May Concern:

I have used the ErgoTorq line of products in the plants that I have launched for the past 5 years.

As a result, we have prevented countless tooling operator injuries from an inherent "pinch point hazard" that exists between the front of nutrunner tooling and their driven attachments, with this product.

I would recommend that anyone who is interested in employee safety, seriously consider buying this quality product and mandating it's use in their assembly process. ErgoTorq products work.... period!!!!

Brad Perry
Advanced Quality Engineer/Process Engineer
Johnson Controls Inc.

STANLEY[®]

Assembly Technologies

Contact Stanley today!

Toll-Free: (877) 709-8006

Tel: (440) 461-5500

www.StanleyAssembly.com

Stanley Output Accessories

ErgoTorq™ Guided Extension Collars

Improve ergonomics by minimizing tool vibration for socket extensions

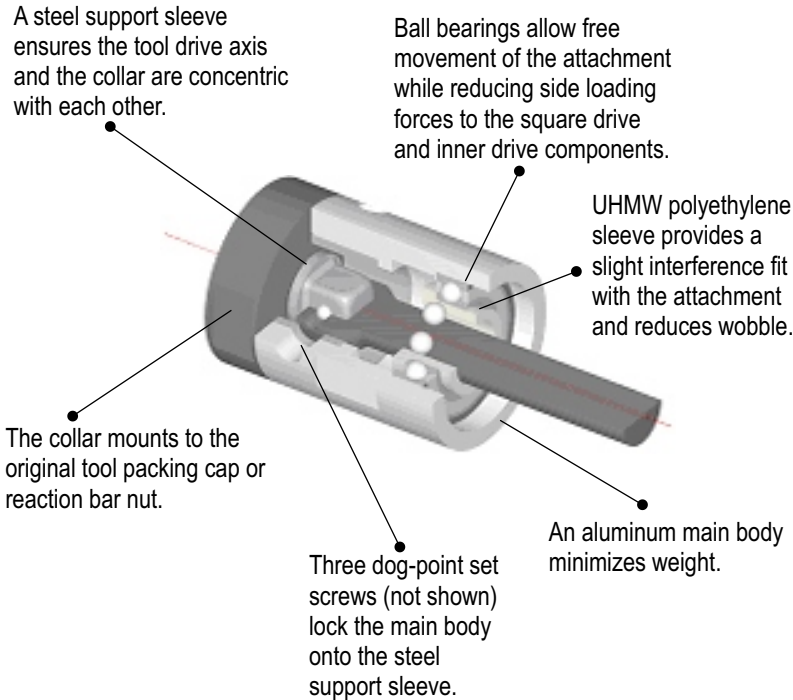

ErgoTorq Guided Extension Collars can help to improve:

- **Ergonomics** - ErgoTorq Guided Extension Collars significantly reduce the transfer of vibration to the operator.
- **Safety** - ErgoTorq Guided Extension Collars minimize the pinch hazard between the tool and the extension.
- **Product Quality** - ErgoTorq Guided Extension Collars reduce the potential for product damage by helping to prevent tool contact with finished surfaces and cross-threading caused by improper fastener installation.
- **Tool Torque Quality** - ErgoTorq Guided Extension Collars assure more consistent driving torque and improve capability.
- **Tooling Reliability** - ErgoTorq Guided Extension Collars incorporate a heavy-duty bearing that minimizes wobble and reduces side-loading to reduce premature tool wear and improve tool reliability.

ErgoTorq Guided Extension Collar tool upgrades require ErgoTorq Standard weight or ErgoTorq Ultralite extensions. ADD PART # INFO

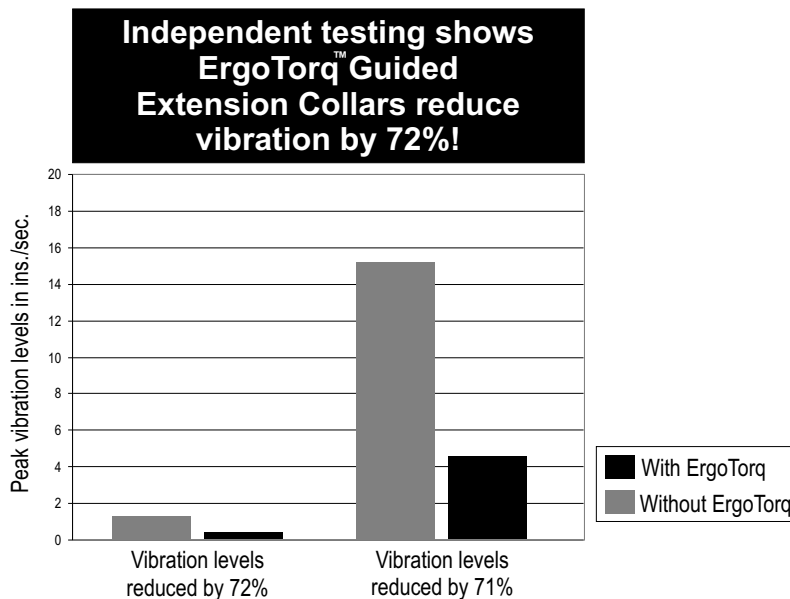

QPM Guided Extension Collars

Part No.	Output	Square Drive
20D243003	A13	3/8"
20D243103	A14	3/8"
20D243206	A18	1/2"
20D243203	A18	3/8"
20D243306	A19	1/2"
20D243303	A19	3/8"
20D243406	A22	1/2"

QPM Guided Sockets

Part No.	Output	Square Drive
20D243001	A13	3/8"
20D243101	A14	3/8"
20D243204	A18	1/2"
20D243201	A18	3/8"
20D243304	A19	1/2"
20D243301	A19	3/8"
20D243407	A22	1/2"

STANLEY®

Assembly Technologies

Contact Stanley today!

Toll-Free: (877) 709-8006

Tel: (440) 461-5500

www.StanleyAssembly.com